

Dec. 17, 1929.

R. F. LAMAR

1,739,725

MERRY-GO-ROUND

Filed Aug. 29, 1927

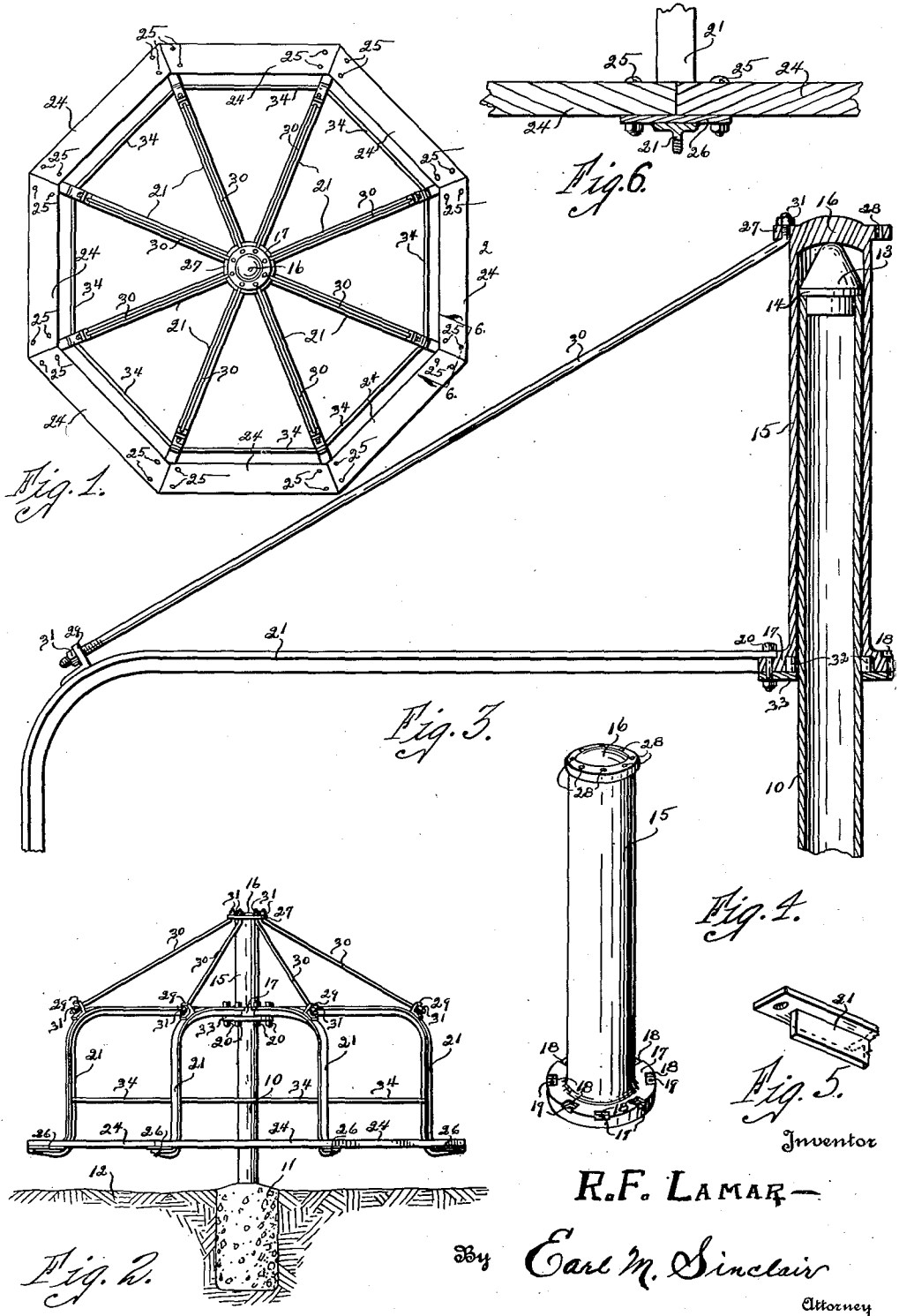

Fig. 1.

Fig. 6.

Fig. 3.

Fig. 4.

Fig. 5.

Fig. 2.

Inventor

R. F. LAMAR

Carl M. Sinclair

Attorney

UNITED STATES PATENT OFFICE

RALPH F. LAMAR, OF PUEBLO, COLORADO

MERRY-GO-ROUND

Application filed August 29, 1927. Serial No. 218,162.

The principal object of this invention is to provide a self-propelled merry-go-round for children.

More specifically, the object of this invention is to provide a self-propelled merry-go-round, an axle having one of its ends buried in suitable material, a hub rotatably mounted on the axle and having radially extending supporting arms, properly braced, for carrying a platform to accommodate the seating of children.

A still further object is to provide a playground device that will promote group playing among the children.

A still further object is to provide a self-propelled merry-go-round that is so constructed that it will not be dangerous to children using and enjoying it.

A still further object is to provide a self-propelled merry-go-round that is economical in manufacture, artistic in design, and durable in use.

A still further object is to provide a self-propelled merry-go-round that is easily rotated and does not necessitate the use of oil.

These and other objects will be apparent to those skilled in the art.

My invention consists in the construction, arrangement and combination of the various parts of the device, whereby the objects contemplated are attained as hereinafter more fully set forth, pointed out in my claims and illustrated in the accompanying drawing, in which:

Fig. 1 is a top plan view of my complete invention.

Fig. 2 is a side view of my complete merry-go-round installed and ready for use.

Fig. 3 is a side sectional view of the upper portion of the axle, the hub, and one of the radially extending supporting arms, for more fully illustrating their construction.

Fig. 4 is a perspective view of the hub portion of the device.

Fig. 5 is a perspective view of a portion of the end of one of the supporting arms designed to be secured to the hub.

Fig. 6 is a sectional view taken on line 6-6 of Fig. 1, illustrating the manner of securing

the platform of the device to each of the free ends of the supporting arms.

Merry-go-rounds have for many years, furnished children with real enjoyment and amusement. However, their indulging in this form of recreation has been much restricted, due to the fact that the merry-go-round had to be operated by older people, was to a great degree dangerous, and was costly.

The necessity was for a small, safe, manually propelled device that could be easily installed in any yard, gymnasium, school ground, or park. Such a device would promote group playing for children, thereby keeping them away from mischief and objectionable amusement. With these facts in mind, I have provided a safe self-propelled merry-go-round of a simple construction, as will be appreciated by those familiar with the art.

I have used the numeral 10 to designate a hollow axle designed to be held in a vertical position by having its lower end embedded in concrete 11, which in turn is in the ground or flooring 12, as shown in Fig. 2. Having its lower end entering the top of the hollow axle, is the cone 13, preferably of cast iron and which is supported on the upper marginal edge of the hollow axle by the peripheral flange 14 integrally formed on the same. The numeral 15 designates a hub designed to embrace the upper portion of the axle 10. The upper end of this hub 15 is closed, as shown in Fig. 3, to form a bearing member 16 designed to support the hub by engaging the cone 13. This bearing member is preferably made of chilled cast iron and is therefore of much harder material than the cone 13. This difference in the metals eliminates the necessity of oiling, as is well known in the art. By the cone 13 being of the softer metal, it will be the first to wear out and can be easily and readily replaced by inserting a new one in the top of the hollow axle. Integrally formed on the bottom of the hub member is the peripheral flange 17. Spaced apart and in the upper surface of this peripheral flange are the notches 18, each registering with the holes 19 passing through the peripheral

flange. Having one end secured in each of these notches by a bolt 20 is a supporting arm 21, preferably T-shaped in cross section except the portion that extends into the notch, as shown in Fig. 5. To remove the supporting arms from the peripheral flange, it is merely necessary to remove the bolts 20. These arms extend outwardly, downwardly and then outwardly to support the merry-go-round platform a short distance from the ground. This platform consists of a series of boards 24 held together and secured to the supporting arms by the bolts 25 and plates 26, which are secured to the free ends of the supporting arms by spot welding or the like. The numeral 27 designates a peripheral flange integrally formed on the upper end of the hub 15 having a plurality of holes 28. Secured by spot welding or other suitable means to each of the supporting arms at a point where they start to extend downwardly, is a lug 29. Passing through each one of these lugs and one of the holes 28 in the peripheral flange 27 as shown in Fig. 3 is a brace rod 30. Threaded onto each end of each of these brace rods is a nut 31. By tightening the lower nut 31 on each of these brace rods, the complete device will become rigid and durable. To facilitate the easy rotation of the complete device, I have provided the roller bearings 32 between the lower portion of the hub 15 and the axle 10, as shown in Fig. 3. These roller bearings are held from falling out of this position by the washer 33 secured to the lower marginal edge of the hub by the bolts 20. The numeral 34 designates a hand rail a slight distance above the platform 24 secured to the supporting arms 21 by suitable means.

By having all the parts bolted together, the complete device may be easily and readily torn down, or assembled. This also permits a broken part to be easily removed and replaced with a new one.

The proper seating of the two bearing members and the elimination of loose bearings throughout the life of the merry-go-round are assured by the member 13 being cone-shaped, as will be understood by those skilled in the art. Little or no friction is experienced on the roller bearings 32. By the above described construction, the complete device rotates very easily.

There is no lateral play. The children may either start the merry-go-round to rotating and then climb on the platform and ride until the momentum is retarded to such an extent as to cease to be enjoyable or one of the group may rotate the device from a position on the ground while the others ride. The device should of course, be so installed that the platform is very low or near to the ground in order that the children can, if they desire, sit on the platform and propel the device by their feet. By the brace rods all being above

the supporting arms, a great degree of safety is attained as there are no cross bars or projections anywhere to strike children not actually riding on the platform. The outwardly extending portions of the supporting rods are high above the heads of the children, thereby eliminating any danger of one of them being injured by falling inwardly while the merry-go-round is in motion.

Once the device is properly installed, it needs no further attention and can be enjoyed and operated safely by the children themselves without the supervision of an older person.

Some changes may be made in the construction and arrangement of my improved merry-go-round without departing from the real spirit and purpose of my invention and it is my intention to cover by my claims any modified forms of structure or use of mechanical equivalents which may be reasonably included within their scope.

I claim:

1. In a device of the class described, an axle designed to be held in vertical position by having one of its ends buried in suitable material, a hub rotatably mounted on the upper portion of said axle, arms extending from the bottom of said hub member first outwardly then downwardly and then outwardly, a circular platform supported on the last mentioned outwardly extending portion of said arms, each of said arms being integrally formed, whereby to provide a relatively immovable support for said platform, a lug secured to each arm at a point where it starts to extend downwardly, said lugs each having a hole, a brace rod extending through each of said holes, and secured to the upper portion of said hub, and a nut threaded onto each of said rods for shortening the distance between the lug and the upper portion of said hub.

2. A device of the class described comprising an axle rigidly supported in a vertical position, a sleeve-like hub rotatably mounted on the upper portion of said axle, said hub being formed with peripheral flanges spaced one above the other, a series of arms each having one end rigidly secured to the lowermost flange of said hub, said arms extending outwardly and then downwardly and being formed near their free ends with laterally extending supporting members, an annular platform mounted on and rigidly secured to the supporting members of said arms, a lug rigidly secured to each of said arms near the upper ends of their downwardly extending portions, a series of brace rods secured at one end each to the upper flange of said hub, each of said brace rods extending loosely through one of said lugs and being threaded, and a nut adjustably mounted on each of said brace rods in engagement with the lug through which it passes.

3. In a device of the class described, a ver-

- tically arranged axle, a hub member rotatably mounted on the upper portion of said axle, arms extending radially from the lower portion of said hub member and then downwardly and having outwardly extending supporting portions, a substantially annular platform mounted on said supporting portions, each of said arms being rigid throughout its length whereby to provide a relatively immovable support for said platform and permitting it to move only in an annular path, an apertured lug secured to each arm near the point where it starts to extend downwardly, brace rods secured to the upper portion of the hub member and each extending through one of said apertured lugs, and a threaded member adjustably mounted on the end of each brace rod in contact with the outer face of one of said lugs.
4. A device of the class described comprising an axle rigidly supported in a vertical position, a sleeve-like hub rotatably mounted on the upper portion of said axle, said hub being formed with peripheral enlargements spaced one above the other, a series of arms each having one end secured to the lowermost enlargement of said hub, said arms extending outwardly and then downwardly, a substantially annular platform secured to the lower end portions of said arms, a lug rigidly secured to each of said arms near the upper end of its downwardly extending portion, a series of brace rods secured at their upper ends to the upper enlargement of said hub, and means for adjustably connecting the lower ends of said brace rods to said lugs.
5. A device of the class described comprising an axle rigidly supported in upright position, a sleeve-like hub rotatably mounted on the upper portion of said axle, said hub being formed with peripheral flanges spaced one above the other, a series of arms each having one end rigidly secured to one of the flanges of said hub, said arms extending outwardly and downwardly, a substantially annular platform supported at the ends of said arms, and a series of brace rods secured each at one end to the other flange of said hub and at the opposite end to an intermediate portion of one of said arms, said arms, braces and platform being rigidly connected to form a unitary structure and to cause said platform to travel in a fixed annular path.
6. A device of the class described comprising a vertically arranged axle or mast, a hub member rotatably mounted on said axle, arms extending radially from said hub member and then downwardly and having outwardly extending supporting portions, a substantially annular platform mounted on said supporting portions, each of said arms being rigid throughout its length whereby to provide a relatively immovable support for said platform and permitting it to move only in an annular path, an apertured lug secured to each arm near the point where it starts to extend downwardly, brace rods secured to the upper portion of the hub member and each extending through one of said apertured lugs, and a holding member mounted on each brace rod in engagement with the outer face of the corresponding lug.
- RALPH F. LAMAR.